



RV

12V MOTORIZED LATERAL ARM AWNING



Read this manual before installing or using this product. Failure to follow the instructions and safety precautions in this manual can result in personal injury and/or cause the product to not operate properly.



Single Pitch

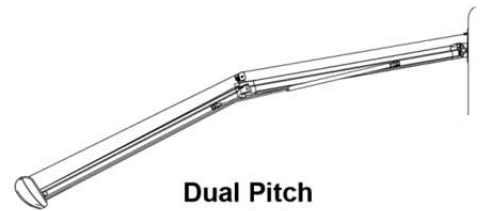

Dual Pitch

FL045

TABLE OF CONTENTS

Product Overview 1
 Component Checklist..... 1

Installation 2
 Pre-Installation Requirements 2
 Mounting the Awning 2
 Attaching the Canopy 3
 Secure the Awning 3
 Remove the Temporary Assembly Pins 3
 Adjusting the Arm Position 4
 Jumping the Motor (when Direct Response is Installed) 4
 Jumping the Motor (without Direct Response)..... 4
 Adjusting the Pitch 5

Switch Installation..... 7
 Wiring Diagram - LCDR 8

LED Lighting 9
 Switch Installation 9

PROPRIETARY STATEMENT

The Latitude Awning is a product of Carefree of Colorado, located in Broomfield, Colorado, USA. The information contained in or disclosed in this document is considered proprietary to Carefree of Colorado. Every effort has been made to ensure that the information presented in the document is accurate and complete. However, Carefree of Colorado assumes no liability for errors or for any damages that result from the use of this document.

The information contained in this manual pertains to the current configuration of the models listed on the title page. Earlier model configurations may differ from the information given. Carefree of Colorado reserves the right to cancel, change, alter or add any parts and assemblies, described in this manual, without prior notice.

Carefree of Colorado agrees to allow the reproduction of this document for use with Carefree of Colorado products only. Any other reproduction or translation of this document in whole or part is strictly prohibited without prior written approval from Carefree of Colorado.

SAFETY INFORMATION



This is the safety alert symbol. It is used to alert individuals to potential personal injury hazards. Obey all safety messages that follow this symbol to avoid possible personal injury or death.



Indicates a hazardous situation, which if not avoided, could result in death or serious bodily injury.

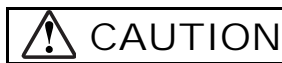

Indicates a hazardous situation, which if not avoided, may result in minor or moderate bodily injury.



Indicates a situation that may result in equipment-related damage.

General Safety:



This product can expose you to chemicals including Di-isodecyl phthalate (DIDP), Vinyl Chloride and Formaldehyde, which are known to the state of California to cause cancer or birth defects or other reproductive harm. For more information visit www.P65warnings.ca.gov



Shock Hazard. Always disconnect battery or power source before working on or around the electrical system.



Always wear appropriate safety equipment (i.e. goggles).



Always use appropriate lifting devices and/or helpers when lifting or holding heavy objects.

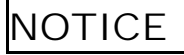

When using fasteners, do not over tighten. Soft materials such as fiberglass and aluminum can be "stripped out" and lose the ability to grip and hold.

PRODUCT OVERVIEW

The Latitude Awning is a state of the art lateral arm awning. Each unit is equipped with lateral support arms. No vertical arms interfere with coach sidewalls, custom graphics or equipment mounted on the sidewalls.

- Fully retractable and self-storing;
- Available in two configurations: single stage or dual stage;
- The awning motor operates on standard 12VDC (range 10VDC to 14VDC);
- Single touch operation for extend and retract;
- LED lights standard, mounted in roller tube.

SPECIFICATIONS

Length	Single Stage	10' 4" – 20' [3.15m – 6.1m]					
	Dual Stage	10' 4" – 18' [3.15m – 5.49m]					
Support:	Lateral Spring Arms						
Motor:	Power: 10VDC–14VDC		Circuit Rating: 15 amp				
(motor is mounted in RH roller tube head)							
Power Source:	Motor and controls are routed and hardwired into the vehicle's 12V system						
Controls:	Carefree Direct Response (to be phased out in 2019) BT12 Wireless Awning Control System						
Color:	Hardware:	White or Black					
	Fabric:	Heavy Duty Vinyl with Weatherguard or FLXguard (refer to sales literature for colors)					
Weight:		10' 4"	12'	14'	16'	18'	20'
	Single Stage	45.5 lbs.	48.3 lbs.	51.7 lbs.	55.0 lbs.	58.3 lbs.	61.6 lbs.
	Dual Stage	52.1 lbs.	55.9 lbs.	60.4 lbs.	65.0 lbs.	69.6 lbs.	n/a

COMPONENT CHECKLIST

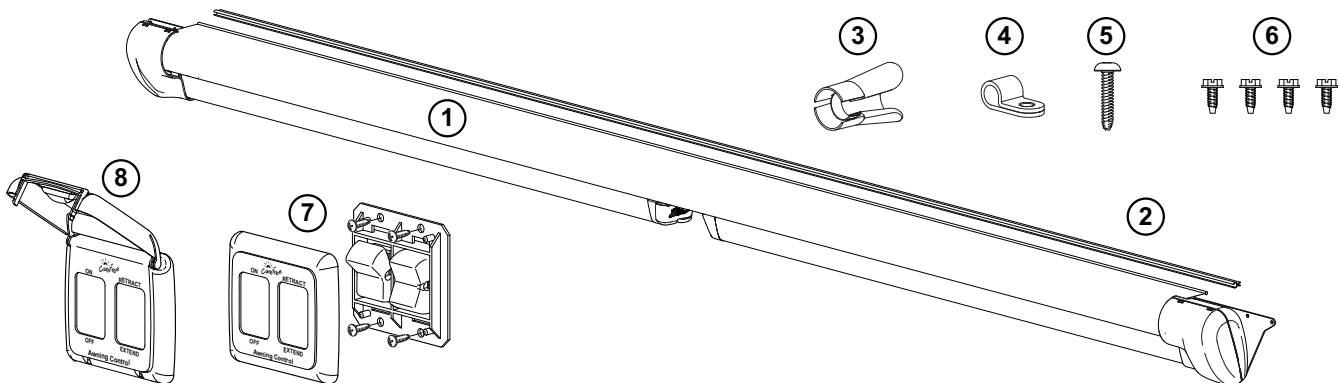

FL011

<input checked="" type="checkbox"/>	ITEM	DESCRIPTION	QTY	NOTE
<input type="checkbox"/>	1	Awning Assembly	1	
<input type="checkbox"/>	2	QuicKonnnect	1	
<input type="checkbox"/>	3	Canopy Funnel	1	
<input type="checkbox"/>	4	Clamp, Cable	1	
<input type="checkbox"/>	5	Screw, PPH	1	#8 x 1"
<input type="checkbox"/>	6	Screw, HWHC	4	#6 x 3/8"
<input type="checkbox"/>	7	Switch Kit, Direct Response	1	4
<input type="checkbox"/>	8	Covered Bezel, 2 Switch	1	3

- Notes:
1. Awning configuration is specified at time of order, including awning length, fabric, color and electronics. Check awning assembly against original purchase order.
 2. Mounting screws are ordered separately. Available in single awning or master pack quantities. 2 screw styles available: 1/4-20 x 1 self-drilling screws or 1/4 x 2" lag screws. Screws available in White or Black.
 3. The covered bezel (item 8) is optional and ordered separately. Refer to page 7 for information about NFPA 1192 RV Standard, Section 6.4.9 (Switch Installation Requirements)
 4. Item 7 is furnished with the BT12 Wireless Awning Control System kit when ordered.

INSTALLATION

PRE-INSTALLATION REQUIREMENTS

1. Ensure that the awning will not interfere with light fixtures, exhaust vents, openings, etc. The mounting area should be clear a minimum of 6" below the awning rail and the full mounting length of the awning.
2. Actual mounting length is 2.6" longer than the stated awning length.
3. The brackets must be secured to a backing plate as large as the brackets. The backing plate must be fully attached to the structure of the vehicle.
 - Aluminum backing plates must be a minimum .125" thick.
 - Steel backing plates must be a minimum 13 gauge (.09" thick).
 - Wood backing plates must be thick enough to allow a minimum of 1.5" of thread engagement.
4. *For single stage awnings:* The bottom of the awning rail should be a minimum of 11.5" above a door opening or slide out (whichever is higher).
5. *For dual stage awnings:* The bottom of the awning rail should be a minimum of 7.5" above a door opening or slide out (whichever is higher).

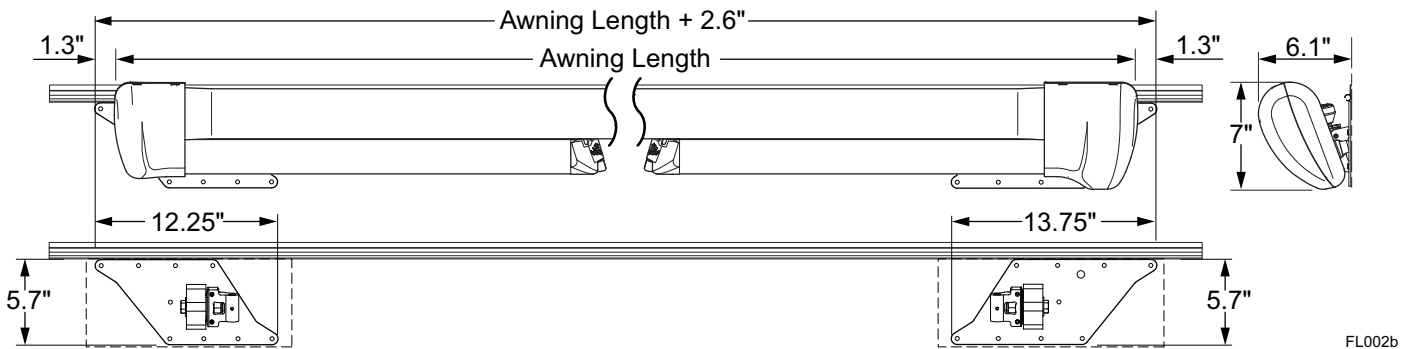

MOUNTING THE AWNING

⚠ CAUTION Do not remove any of the shipping wrap around the roller tube, the ties around the arms or the temporary assembly pin in the idler head until instructed to do so in the installation steps.

It is recommended that 2 people lift and hold the awning while a third person installs the screws.

NOTE: While attaching the screws, apply a quality silicone sealant around the screws and holes.

1. Lift the awning up to the desired location and place the top of the brackets against the bottom of the awning rail.
2. Attach the brackets through the exposed holes. Additional screws will be added later.

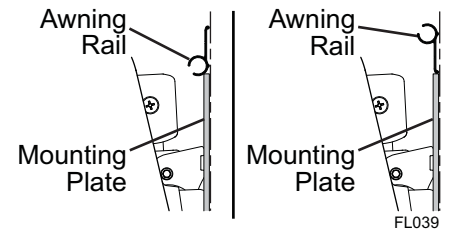

NOTICE For proper awning operation, the mounting plates must be parallel to the awning rail.

- 2.1. Place the first screw in the outside upper screw hole.
- 2.2. Lift the arm up to force the plate parallel with the awning rail, place the second screw in the lower inside hole.
- 2.3. Place screws in the remaining exposed holes.
- 2.4. Repeat for the other side

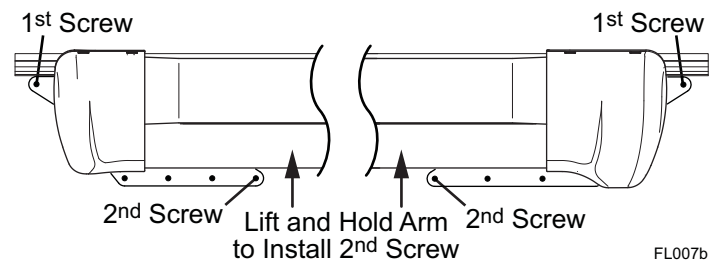

Notes about screws:

- For installations using metal backing plates: Attach using 1/4 x 1" self-drilling screws. The screws must be long enough for the threads to reach through the backing plate.
- For installations using wood backing plates: Attach using 1/4 x 2" lag screws. The screws must be long enough to provide a minimum of 1.5" of thread engagement in the wood.

Attaching the Canopy

After the awning arms have been attached, it will be necessary to attach the canopy to the awning rail.

1. Unwrap the plastic wrap from the roller tube and fabric. DO NOT remove the tie straps holding the arms.
2. Unwrap the fabric over the roller tube and toward the awning rail.
3. Slip the fabric funnel onto the QuickConnect.
4. While holding the fabric, simultaneously slide the QuickConnect into the awning rail and over the canopy.
5. Center the fabric and QuickConnect with the roller tube.
6. Remove the funnel from the QuickConnect.
7. Secure the fabric and QuickConnect:
 - 7.1. Place one (1) #6 x 3/8" screw (a) through the QuickConnect, fabric and polyrod approximately 1" in from the fabric edge.
 - 7.2. Place one (1) #6 x 3/8" screw (b) through the awning rail outside the end of the QuickConnect (not through the QuickConnect).
 - 7.3. On the other end of the QuickConnect place one (1) #6 x 3/8" screw (c) through the awning rail outside the end of the QuickConnect (not through the QuickConnect).
 - 7.4. Pull the fabric tight in the QuickConnect then place one (1) #6 x 3/8" screw (d) through the QuickConnect, fabric and polyrod approximately 1" in from the fabric edge.
8. While holding the roller tube, remove the ties holding the arms.
9. Allow the roller tube to extend until the fabric is taut.

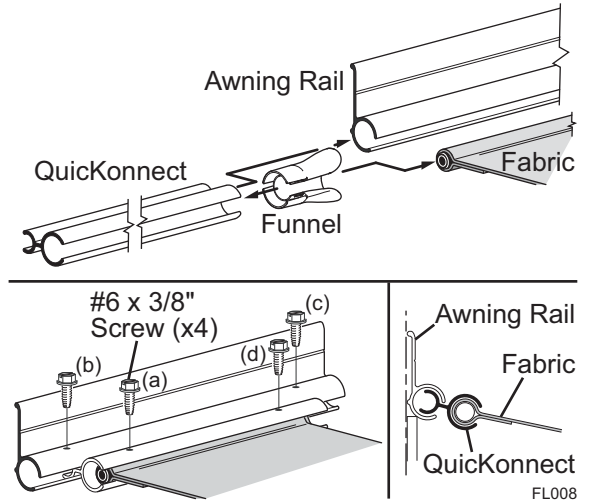

NOTICE The awning installation is not complete. Except as directed, the awning should not be operated until completing all installation instructions including Adjusting the Arm Position.

Secure the Awning

Before operating the awning, it is necessary to finish securing the awning to the vehicle wall.

1. Open the awning approximately 18" to access the mounting plate. To open, follow the directions in "Jumping the Motor" on page 3. Do not close the awning except as noted in the instructions.

NOTICE Disconnect the battery after opening the awning to prevent unexpected awning motion.

2. Finish attaching the mounting plates using the same self-drilling 1/4 x 1" screws or the 1/4 x 2" lag screws used to initially mount the awning.
3. In the area shown, drill a 3/8" hole into the vehicle. Deburr and clean the hole. This is for the wire routing.
4. Route the motor cable from the arms and the LED harness from the canopy through the hole drilled previously. After routing, seal the hole and wires with a quality silicone sealant.

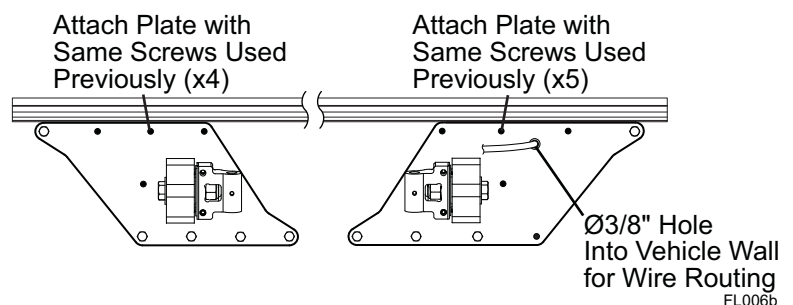

Remove the Temporary Assembly Pins

Two pins are inserted into the back of the left (idler) head for lateral stability during installation. Using a pair of pliers, remove and discard the pins.

NOTICE Before operating the awning except as noted, the temporary pins must be removed. Failure to remove the pins may cause the awning to not operate correctly.

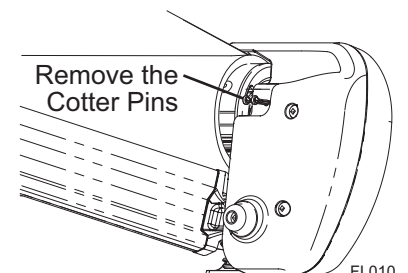

Adjusting the Arm Position

For the awning to operate and close correctly, the arms must be parallel to the roller tube. If the arm sags, the arm position can be adjusted to bring the arm parallel.

1. Partially close the awning leaving the roller tube 6" to 7" from the wall to access the adjustment screws located on the side of the arm knuckle at the wall.
2. Loosen the upper screw (counterclockwise).
3. Tighten (clockwise) the lower screw to raise the arm elbow.

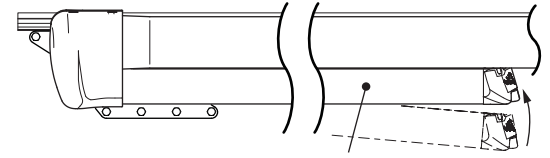
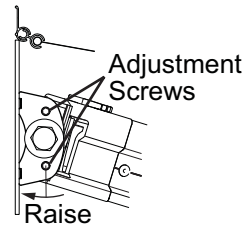

Adjust Arm to be Parallel to Roller Tube
FL013

- NOTE:** Make adjustments in quarter turn increments.
4. Repeat steps 2 and 3 until the arm is parallel with the roller tube.

JUMPING THE MOTOR (WHEN DIRECT RESPONSE IS INSTALLED)

To open the awning before the switch and wiring are complete, it is possible to jump the motor to open the awning.

1. Separate the wires at the end of the harness cable.
2. Attach the RED wire to the positive terminal of a 12-14V battery.
3. Attach the BLACK wire to the negative terminal of the battery.

NOTE: The awning circuitry includes "Reverse Polarity Protection" if the battery connections are accidentally reversed the awning electronics will not be damaged. If the wires are reversed, remove and reconnect in the correct order.

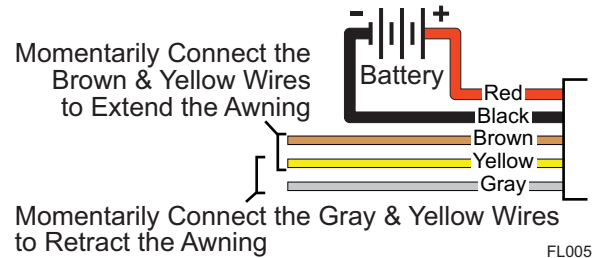

4. To extend the awning: Momentarily connect the BROWN and YELLOW wires together. It is not necessary to hold the wires together while the awning is moving.
5. To stop the awning while extending: Momentarily connect the BROWN and YELLOW wires together again.
6. To retract the awning: Momentarily connect the GRAY and YELLOW wires together. It is not necessary to hold the wires together while the awning is moving.
7. To stop the awning while retracting: Momentarily connect the GRAY and YELLOW wires together again.
8. Disconnect the battery after performing the desired operation.

JUMPING THE MOTOR (WITHOUT DIRECT RESPONSE)

This method is used if the BT12 Wireless Awning Control System is to be used.

To open the awning before the switch and wiring are complete, it is possible to jump the motor to open the awning.

1. Temporarily connect the ends of the motor wires to a 12V-14V source (i.e. drill battery). If the awning does not begin to move, reverse the leads.
2. Remove the battery after the awning is open.

ADJUSTING THE PITCH

The awning pitch can be adjusted. It is strongly recommended that adjustments be made in small increments to achieve the desired setting.

This procedure works best with 2 people. One person to lift the roller tube to relieve the weight and one person to make the adjustments. **DO NOT USE POWER TOOLS, ALWAYS USE HAND TOOLS TO MAKE ADJUSTMENTS.**

1. Open the awning.
2. At the top of the knuckle loosen the locking screw approximately 1/4".

NOTICE The locking screw **MUST** be loosened before adjusting the pitch.

3. To raise the pitch: Turn the lower adjustment screw clockwise.
4. To lower the pitch: Turn the lower adjustment screw counterclockwise.
5. Hand tighten the locking screws until snug when the desired pitch is achieved.

NOTICE Do **NOT** overtighten the locking screw. Overtightening the screw can cause unnecessary strain and wear on the knuckle.

Important Note: After the initial installation and the awning is opened, the awning may settle. This is normal. Check that the locking screws on the knuckle are snug.

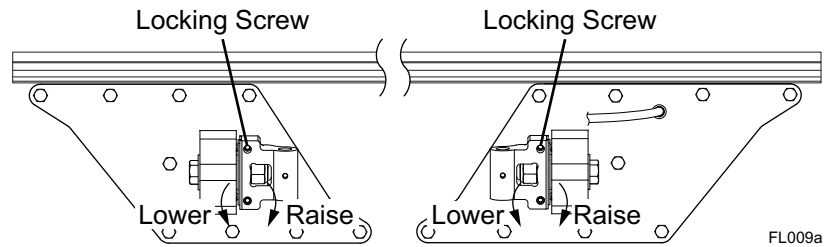



If installing the BT12 Wireless Awning Control System use the wiring and setup instructions in “070029-001 BT12 Installation Manual”.

Manual is available on-line at www.carefreeofcolorado.com/carefreeconnects.

SWITCH INSTALLATION



WARNING Shock Hazard. Always disconnect battery or power source before working on or around the electrical system.

NOTICE

To comply with 2018 NFPA 1192 RV Standard, Section 6.4.7, switches must be mounted as follows:

For travel trailers and 5th wheels:

- Installed in a dedicated switch cabinet with a latching door; or,
- Installed with the optional covered bezel available from Carefree; or,
- Installed in a cabinet with a latching door where the switch is protected and CANNOT be activated by any items or cargo that may move or shift during transit; or,
- Installed with an interrupt circuit that disables awning extension when the vehicle is in motion (i.e. a relay tied into the parking brake or ignition that disconnects the BROWN extend wire).

For motorized coaches (Class A, Class B or Class C):

- Installed with an interrupt circuit that disables awning extension when the vehicle is in motion (i.e. a relay tied into the parking brake or ignition that disconnects the BROWN extend wire or removes power from the awning controls).

1. At the switch location cut a 2 5/16" [5.9cm] x 1 1/2" [3.8cm] hole.

2. Route the cable from the awning through the hole.

3. Terminate the three (3) 20awg wires (Brown, Yellow, Gray) with .187, 18-20 awg female terminals. Attach to the EXTEND/RETRACT switch as shown in the wiring diagram.

4. Terminate the RED wire from the cable with a .187, 14-16 awg female terminal. Attach to one terminal of the ON/OFF switch.

5. Terminate the BLACK wire from the cable with a .25, 14-16 awg male terminal.

6. Run a minimum 14 awg wire to chassis ground. Suitable ground would be the vehicle chassis or conductive structure connected to the chassis. Terminate the wire with .25, 14-16 awg female terminal and connect to the black wire from the cable.

7. Run a minimum 14 awg wire from the power distribution panel (auxiliary battery circuit) or equivalent. The circuit should be protected by a 15-amp fuse. Terminate the wire with a .187, 14-16 awg female terminal. Attach to one terminal of the ON/OFF switch.

NOTE: If the wire run is 30 feet or longer, use 12awg wire to prevent voltage drop. Use the appropriate wire terminals for the wire size.

8. Push the wires and switches into the hole then attach the switch frame using four (4) #6 x 1/2" screws.

9. Snap the switch bezel over the switch frame.

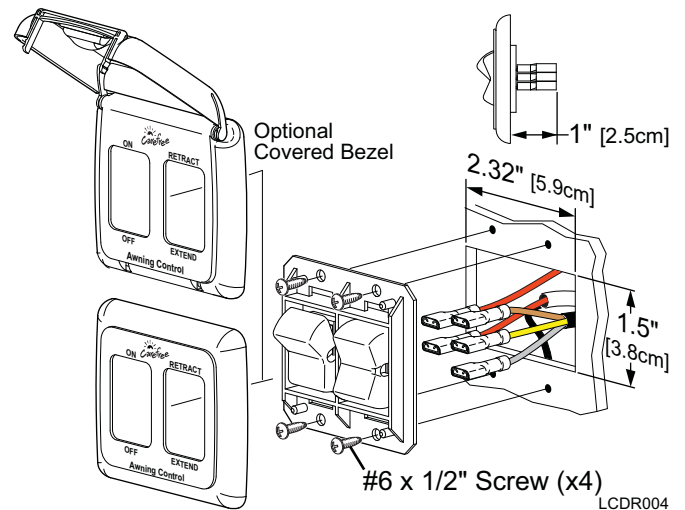

WIRING DIAGRAM - LCDR

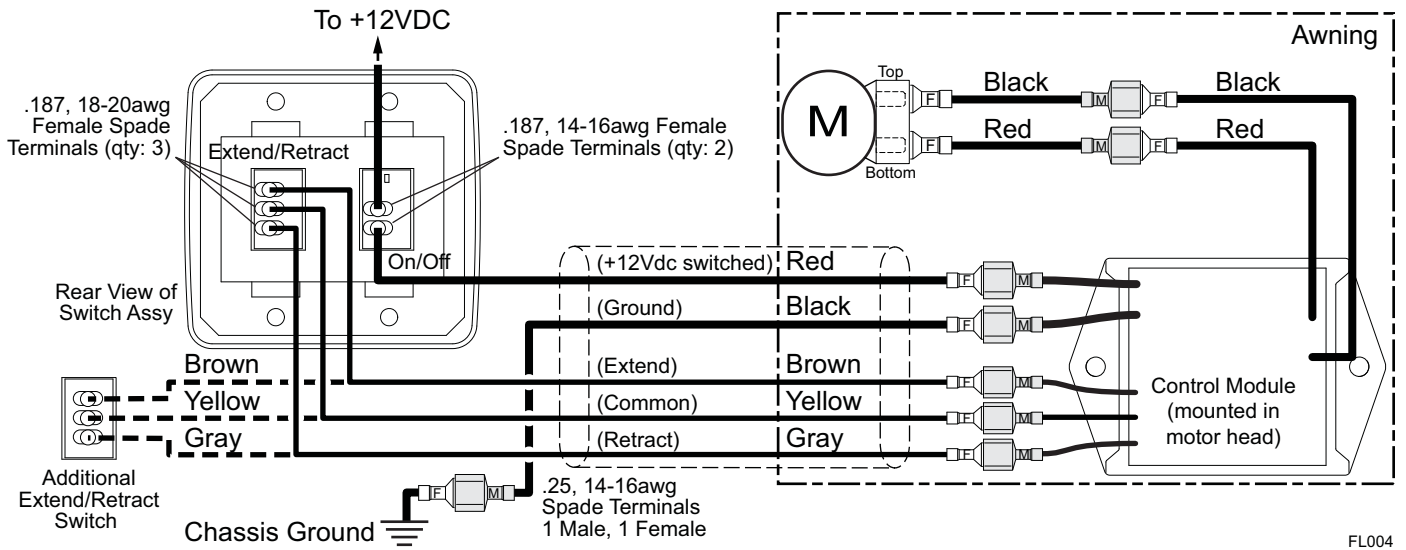

FL004

LED LIGHTING

An LED light strip is standard on the Latitude. The LED strip is mounted in the roller tube with the harness routed through the canopy.

Route the twisted wire cable for the LED lighting into the vehicle with the motor cable. Seal the hole and wires with a quality sealant.

SWITCH INSTALLATION

NOTES:

- Installers may choose to furnish the control switch. The installation requires that the power line (+12VDC) be attached to a dedicated 2A circuit breaker or a 2A in-line fuse must be installed between the switch and power source. For easy access, locate the fuse close to the switch.
- Per RVIA Low Voltage Systems in Conversion and Recreation Vehicles Chapter 3, Section 3-1: For Carefree LED strip lighting near the awning rail: when the 24AWG power harness is spliced or connected 10" or less from the harness connector using a heavier gauge wire, the fuse size is determined by the heavier wire gauge.

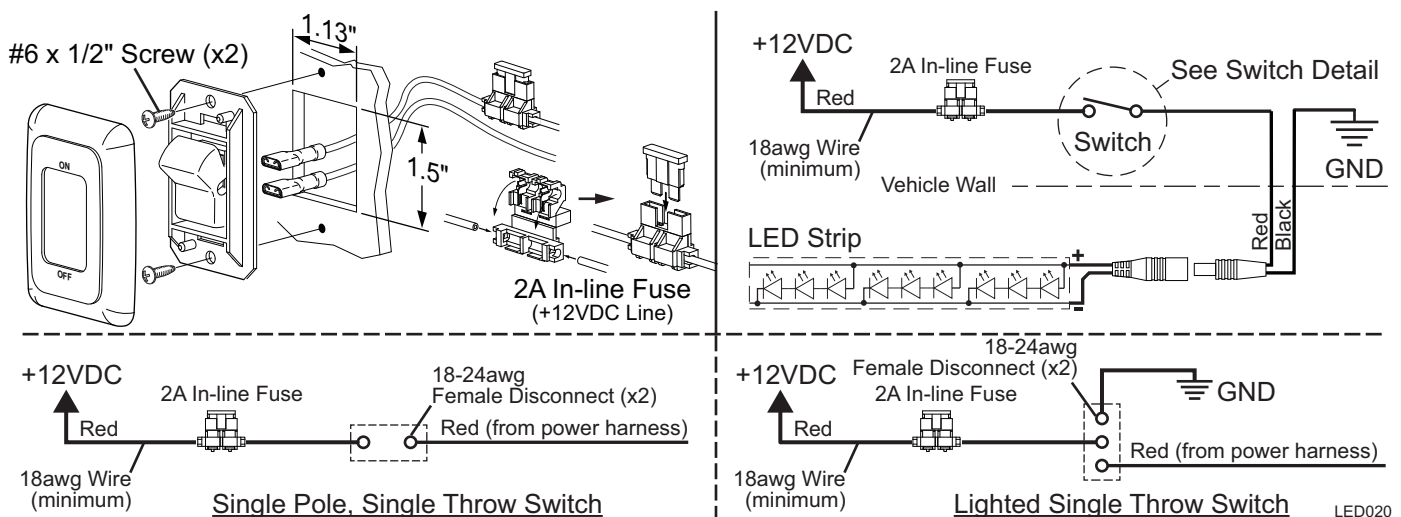

- Determine the location of the switch.
- At the switch location, cut a 1 1/8" x 1 1/2" hole.
- Wire the switch as shown below. Wire terminals at the switch are .187, 18-24 awg female disconnects.

NOTE: Allow adequate slack in the 12VDC power line so that the in-line fuse (installed in step 4) can be accessed from behind the switch.
- Install the in-line fuse:
 - Near the switch, cut the red 12VDC power line to the switch. Do not strip the insulation.
 - Insert a wire end into one of the wire channels until it butts up against the stop.
 - Fold that half of the connector body over until the element contacts the wire. Use pliers to crimp the connector closed.
 - Repeat for the second wire end.
 - Slide the fuse into the fuse port. Ensure that it is firmly seated.
- Press the in-line fuse, wires and switch into the mounting hole. Secure the switch using two (2) #6 x 1/2" screws.
- Snap the switch bezel over the switch frame.